

Chapter 5 - Sampling Considerations

Making good optical measurements involves both art and science, and close attention to method is important for repeatable and accurate sampling. While specific recommended tools and protocols exist, the best method will vary with the particular goal or question, and often we have to “bend the rules” to be able to collect useful data. Regardless of method used, clear definition of sampling protocols is critical for quantitative, repeatable studies.

Sampling Geometry

Good sampling involves consideration of sampling geometry, which typically involves defining the direction of incoming and reflected radiation and the sampling field of view. Optical properties depend upon the specific circumstance, including the nature of the target, the illumination conditions, and view angle. For these reasons, careful evaluation of sampling geometry and definition of terminology can be helpful.

Standard nomenclature has been developed for describing sampling geometry for reflectance (Figure 1). While useful for defining a sampling protocol, these concepts represent idealized circumstances, and, actual sampling methods can only approximate the scenarios shown here, and may actually be far more dynamic and complex. For example, in the real world, as sky conditions change from sunny to cloudy, the nature and angular properties of the incoming radiation will change from primarily directional (under direct sun) to more hemispherical (under overcast skies). In any case, this terminology can provide a useful way to communicate fundamental aspects of sampling geometry relevant to proximal reflectance sampling, and we can try to restrict our sampling to one set of definable conditions.







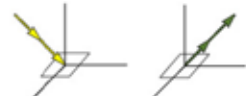

<i>Incoming/Reflected</i>	Directional	Conical	Hemispherical
<i>Directional</i>	Bidirectional Case 1 	Directional-conical Case 2 	Directional-hemispherical Case 3 
<i>Conical</i>	Conical-directional Case 4 	Biconical Case 5 	Conical-hemispherical Case 6 
<i>Hemispherical</i>	Hemispherical-directional Case 7 	Hemispherical-conical Case 8 	Bihemispherical Case 9 

Figure 1. Sampling geometry defined by the patterns of incoming and reflected radiation. Schaeppman-Strub et al. 2006, Milton 2009.

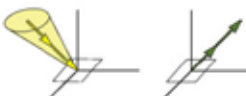
Surface reflective properties

Another important consideration is the angular properties of the surface reflectance itself. Ideally, a surface would be Lambertian (isotropic), but surfaces in nature are rarely Lambertian, often having strong specular (mirror-like) reflective properties (Figure 2), which might influence the choice of sampling geometry (Figure 1).

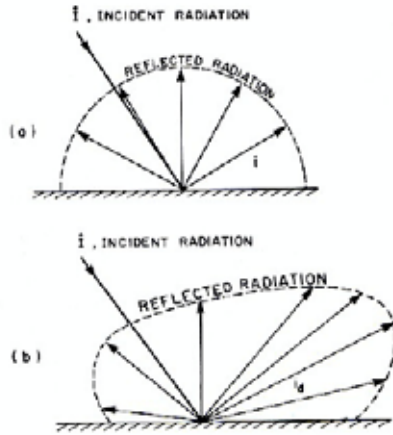

Figure 2

Idealized isotropic (a) and actual non-isotropic (b) targets). Target b shows some degree of specular (mirror-like) reflectance. From Iqbal, 1983.

To characterize the isotropic or non-isotropic qualities of a target, it is helpful to conduct a series of bidirectional measurements over a range of angles, generating a bidirectional reflectance distribution function (BRDF), which can be represented as a polar coordinate or three-dimensional plot illustrating reflectance at different angles for a fixed illumination angle (Figure 3). Often, BRDF functions reveal a characteristic dark area (“cold spot”) and bright area (“hot spot”) for a given target and condition, which might best be avoided if the goal is to obtain a “typical” reflectance value. BRDF function plots can vary in complex ways, and for vegetation surfaces can be quite dynamic due to contrasting structure and responses of plants to changing environmental conditions over a growing season. Even an inanimate surface like a soil background can vary in its angular reflectance properties depending upon moisture status or particle size.

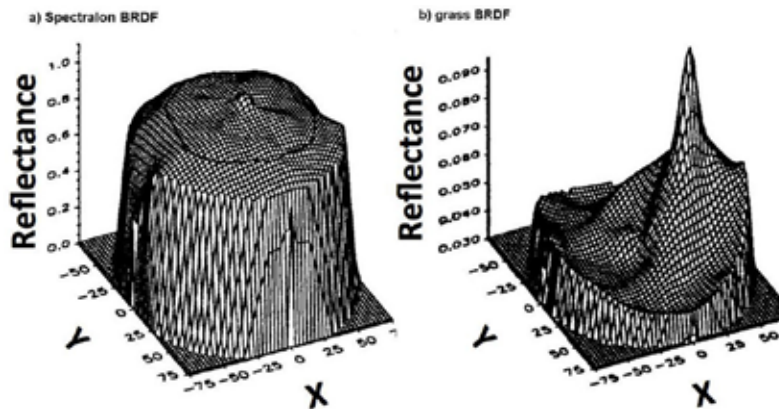

Figure 3 - Bidirectional reflectance distribution functions (BRDFs), represented as polar coordinate plots. A) BRDF for a nearly isotropic surface (“Spectralon,” Labsphere, North Sutton, NH, USA). B) BRDF for a somewhat specular grass surface, showing a strong reflectance dip (“cold spot”) and peak (“hot spot”). Sandmeier et al. 1998.

Field of View

In addition to characterizing illumination and view geometry (Figure 1), the field of view (FOV), which varies with foreoptic and distance, is an important consideration.

In remote sensing, field of view (FOV) typically refers to a solid angle (Figure 4), and can be variously defined by the sampling angle, by the ground sampling area, or the ground sampling diameter (d). By knowing the sampling angle (θ) and height (h) it is possible to calculate the ground sampling diameter (Ground Field Of View, GFOV, also called Instantaneous Field of View, IFOV).

$$d = 2 \times (h \times \text{TAN}(\theta/2)) \quad \text{eq. 1}$$

Where d is the IFOV diameter, h is the sampling height, and θ is the sampling angle expressed in radians. Radians can easily be calculated from degrees using the following formula.

$$\theta \text{ (Radians)} = \theta \text{ (degrees)} \times \pi/180 \quad \text{eq. 2}$$

The sampling angle is typically a function of the instrument foreoptic used. For example, a bare fiber optic typically has a sampling angle (θ) close to 25 degrees, and this can be adjusted by the addition of a lens or field-of-view restrictor (a tube attenuating the view angle). From these simple formulas, it is easy to generate a “rule of thumb” for assessing the proper sampling distance (h) for a given sampling angle or target size, with the goal of ensuring that the IFOV (GFOV) fits within the area of the target (Table 1). This is particularly important when sampling a reference standard, since subsequent reflectance calculations depend upon an accurate reference target measurement.

Table 1 – IFOV values (ground field of view diameter, in meters) for various sampling angles (θ , in degrees) and sampling heights (d), calculated using equations 1 and 2.

θ (deg)	1m Height	2m Height	3m Height	4m Height	5m Height
1	0.02	0.03	0.05	0.07	0.09
3	0.05	0.10	0.16	0.21	0.26
5	0.09	0.17	0.26	0.35	0.44
10	0.17	0.35	0.52	0.70	0.87
15	0.26	0.53	0.79	1.05	1.32
20	0.35	0.71	1.06	1.41	1.76
25	0.44	0.89	1.33	1.77	2.22

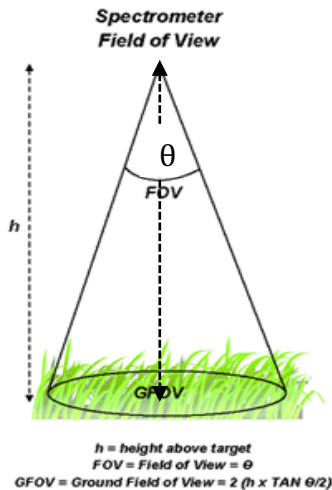

Figure 4

Relationship between sampling angle (θ), distance (h), and sampling area (Ground Field Of View, GFOV, also called Instantaneous Field of View, IFOV).

Source:

<http://discover.asdi.com/bid/97740/Expert-Tip-Understand-Your-Field-of-View-When-Taking-Reference-Measurements>

A common foreoptic is a bare fiber optic “probe” or a fiber optic with a particular lens. Bare fibers or fiber bundles typically provide a sampling angle (field of view) of approximately 25 degrees. This can be narrowed to a desired field of view by extending a tube over the tip of a fiber optic, providing a “field of view restrictor”. Many fiber optics have standard (e.g. SMA - SubMiniature A) connectors, allowing ready connection of lenses and other foreoptics that can provide a defined field of view. When applying these methods, it is important to characterize your sampling field of view, your light source, and your target and to properly define your sampling geometry. Because sampling FOV often deviates from the nominal FOV reported by a manufacturer, conducting an angular calibration of the sensor foreoptics may be necessary.

Sampling scale

The optimal sampling methods will often vary with scale, the nature of the target, and the purpose at hand. Sampling scale can include spatial scale, temporal scale, spectral scale, radiometric scale, angular scale. Scale generally has two aspects, sometimes called resolution (sampling grain size) and extent (Table 2). Scale also has a variety of colloquial definitions, for example *leaf scale*, *canopy scale*, *daily scale*, so it is important to be aware of the context when discussing scale. At a fine scale (e.g. individual leaf samples), one set of methods might be best, but at a coarser scale (e.g. sampling a whole canopy or landscape) another set of methods might be most appropriate. Below, we consider some common sampling scales and methods, using the example of leaves and vegetation plots. Similar considerations may apply to non-vegetated targets.

Table 2 – Various definitions (aspects) of scale, and examples of resolution and extent. Details will vary depending upon sensor and platform.

Scale definition	Resolution (grain size)	Extent
Spatial scale	Pixel size	Spatial extent (area covered)
Temporal scale	Time step sampled (e.g. daily)	Time length sampled (e.g. 1 year)
Spectral scale	Waveband resolution (FWHM)	Wavelength range (e.g. VIS-NIR, 400-1000 nm)
Radiometric scale	Bit resolution	Bit depth (e.g. 12-bits)
Angular scale	Field-of-view (degrees)	Sampling swath width

Leaf sampling

Leaf sampling with an integrating sphere - For sampling leaf optical properties, the “gold standard” is the integrating sphere (also known as the Ulbricht sphere). An integrating sphere consists of a hollow sphere coated in a reflective white material, usually white paint, barium sulfate, or teflon. A well-made integrating sphere approximates an isotropic (Lambertian) illumination and provides a bi-hemispheric sampling geometry (case 9 in [Figure 1](#)). By providing an angularly integrated measure over a full hemisphere, this method avoids some of the problems associated with non-lambertian leaf surfaces (e.g. glossy leaves with strongly specular reflectance).



Figure 5 - Integrating sphere (RTC-060-SF, Labsphere, North Sutton, NH), consisting of a hollow sphere coated in highly reflective teflon material (“Spectralon”). Multiple ports can accommodate a light source, a target (e.g. leaf), and a detector. Separate port configurations are used for reflectance and transmittance sampling.

Integrating spheres can be configured to sample not only leaf reflectance (ρ), but also leaf transmittance (τ). From these, we can also calculate absorptance (α) using the following equation:

$$\alpha + \rho + \tau = 1 \quad (\text{Eq. 3})$$

A particularly useful feature of integrating spheres is that they can provide a comprehensive accounting of the fates of energy striking a target, describing both the absorptance (α) and scattering ($\rho + \tau$) properties of a target. Some applications require this full characterization of absorption and scattering. For example, vegetation radiative transfer models require α , ρ , and τ as separate inputs, making integrating spheres a necessary tool.

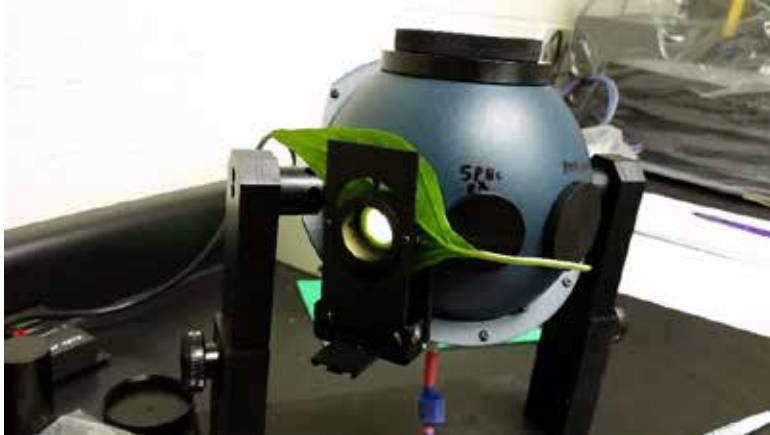

Figure 6

Leaf in transmittance port of an integrating sphere. In this case, a directed white light beam (coming from the left of the image) shining through the leaf illuminates the sphere with transmitted light, which is sampled by a detector attached to the bottom of the sphere.

A key disadvantage of most integrating spheres is that they require that leaves fit in a sampling port, which is larger than many leaves. For example, grass blades, conifer needles, or the small leaves of most arid-climate or tundra plants cannot easily fit into most integrating sphere ports. For this reason, much of the world's vegetation cannot be easily sampled by integrating spheres. Furthermore, the act of removing a leaf and placing it in the sphere changes the leaf environment in ways that affect the leaf physiological and optical properties. These limitations lead us to either adapt our sampling methods or abandon the sphere and consider other methods.

A number of methods have been proposed to sample small or narrow leaves using integrating spheres. For example, some methods for narrow leaves involve taping several leaves closely together, and then sampling the taped assembly as a single "leaf" sample. Because this method cannot properly seal the edges of leaves from light leaks and typically results in overlap of some leaves, this method can lead to large errors in transmittance (and hence absorptance).

Leaf sampling with a leaf clip – Another solution is the leaf clip, which involves placing the leaf in a holder (clip) containing a fiber optic that both delivers light from a light source (the irradiance signal) and delivers the reflected light (the reflected radiance signal) to a detector (**Figure 7**). This method normalizes sampling geometry, and approximates the bidirectional sampling method shown in case 1 (**Figure 1**), except that both the illumination and reflected radiation share a common angle.

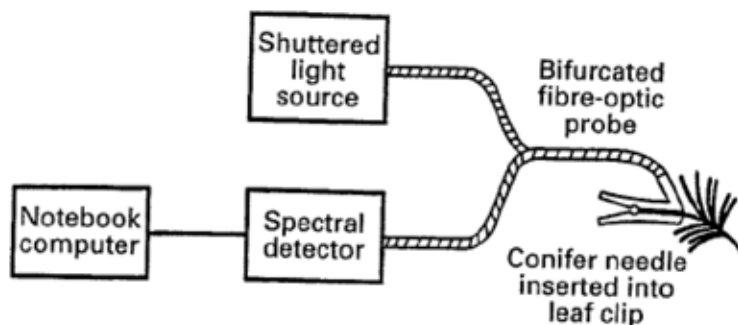

Figure 7

Schematic of a leaf clip attached to a bifurcated fiber optic that both provides illumination and measures reflected radiation from a fixed sampling geometry. From Gamon & Surfus 1999.

Leaf clips come in many designs (Figure 8), with varying consequences for the measured reflectance.



Figure 8a – Leaf clip (Spectral Evolution, Lawrence, MA, USA) sampling leaf reflectance.



Figure 8b – Broadleaf clip (PP Systems, Amesbury MA, USA) sampling leaf reflectance.



Figure 8c - Needle-leaf clip (PP Systems, Amesbury MA, USA) sampling a conifer needle. The needle is held in position by a small groove in the clip. In this case the fiber optic diameter at the common end is 0.6 mm, allowing reliable sampling of very narrow leaves.

A spectrum sampled using leaf clips is typically normalized by dividing the target spectrum by the irradiance spectrum, usually determined as the radiance spectrum of a standard white reference,

$$\rho_{\lambda} = R_{T,\lambda}/R_{S,\lambda} \quad \text{eq. 4}$$

where ρ_{λ} is the reflectance by wavelength (λ), $R_{T,\lambda}$ is the target (e.g. leaf) radiance by wavelength, and $R_{S,\lambda}$ is the standard radiance by wavelength (typically a 99% reflective reference standard, e.g. Spectralon, LabSphere, North Sutton, NH, USA). Note that normalizing to a reflectance standard avoids the need for a radiometric calibration and provides a unitless expression of reflectance.

Depending upon the design of the leaf clip and the reflective properties of the target, reflectance measured with a leaf clip may or may not be comparable to reflectance

measured by an integrating sphere. A key factor is the sampling geometry (Figure 1). Reflectance measured from leaf clips approximating a 60 degree elevation angle (30 degrees from normal, which avoids most specular reflectance) provide a good approximation of reflectance sampled with an integrating sphere, which is one reason why many leaf clip designs use this angle.

Advantages of leaf clips are that they tend to be more portable than integrating spheres, and don't require removal of the leaf, so are more readily adapted to non-destructive, *in-situ* measurements. Leaf clips can be particularly useful for rapid sampling needed to characterize dynamic processes under field conditions. For example, the response of leaf reflectance to diurnal illumination or rapidly changing environmental conditions can be characterized with leaf clips (see Figure 3 in Chapter 2 - Applications). Because measurements can be made quickly, large sample sizes can be collected on attached leaves in the field without seriously disturbing the leaf environment and altering the physiology. A disadvantage is that leaf clips cannot provide a proper leaf transmittance or absorbance measurement comparable to that of an integrating sphere. Because the design of leaf clips varies enormously from one manufacturer to the next (and sometimes even within a manufacturer), measurements made with different brands may not be directly comparable.

Sampling with a sampling probe - Many alternatives to leaf clips and integrating spheres exist for measuring target optical properties. One method is to insert a fiber optic (foreoptic) into a sampling block that holds the fiber at a fixed angle relative to the sample (Figure 9), normalizing the sampling geometry, much like using a leaf clip. Similar sampling probes are commonly used when sampling inanimate objects with flat surfaces, such as soil.



Figure 9 –Sampling leaf reflectance with a reflection probe holder (Ocean Optics, Dunedin FL, USA).

Plot and landscape sampling

Proximal optical sampling also involves larger sampling scales than single leaves, for example mineral surfaces, soil, snow, ice, water, urban surfaces or individual plant canopies, or vegetation stands. For vegetation, sampling above the leaf scale is often loosely called “canopy” sampling, which can be confusing because a canopy can refer to the above-ground portion of a single plant (e.g. a single tree crown or canopy), a stand of

plants, or an entire landscape with multiple patches of vegetation, bare soil, etc. For this reason, clear definition of the spatial scale of sampling (including grain size and extent) is important.

Sampling configurations - The same sampling considerations described above and defined in [Figure 1](#), including illumination angle and view angle, are relevant to measuring plots and landscapes under sunlight ([Figure 10](#)). At this spatial scale, illumination conditions and geometry cannot be easily controlled, but attention to sun angle, view angle, and sky conditions is important for repeatable measurements.

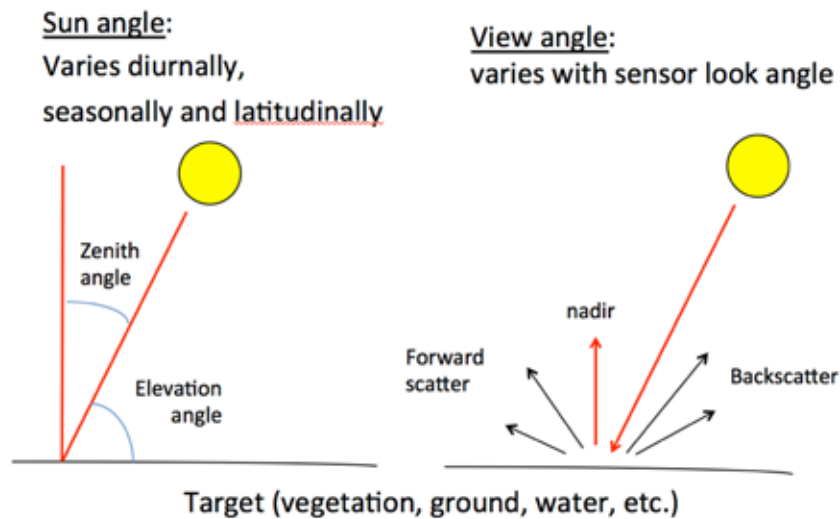

[Figure 10](#) – Sun angle and view angle terminology relevant to reflectance sampling.

Detector configurations - Different sampling configurations, involving single or dual detector systems can be used to sample reflectance outdoors ([Figure 11](#)). Single detector systems ([Figure 11a](#)) are generally cheaper than dual systems, but require alternate sampling of a reference (calibration) panel and the target of interest (plant canopy in this case). This method requires stable illumination, because large changes in illumination during the intervening time cause subsequent errors in the calculated reflectance. For this reason, careful attention to sky conditions is necessary.

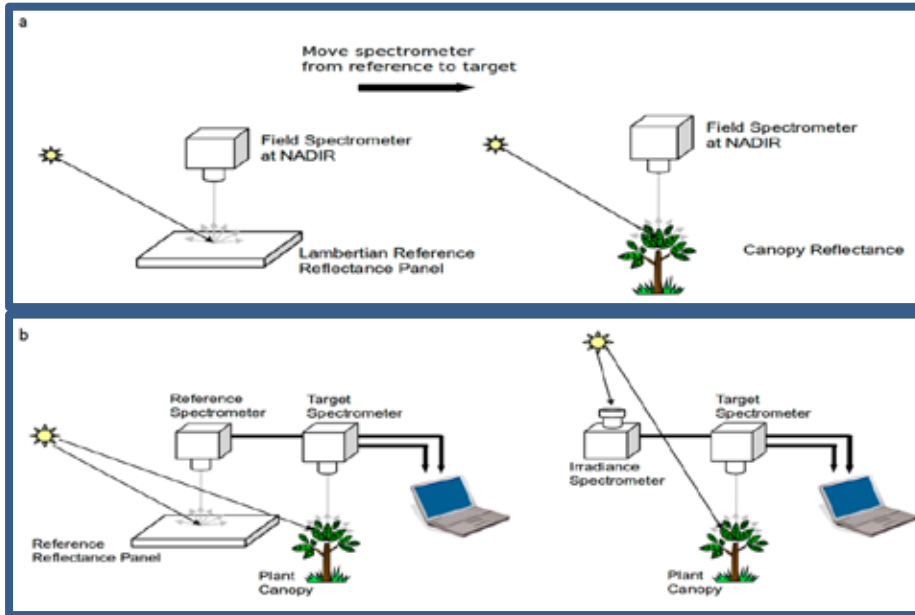

Figure 11 - Configurations for outdoor reflectance sampling involving a single detector (panel a) or dual detectors (panel b). Single-detector methods require alternate sampling of a standard reference target and the sample target. Dual-detector methods allow correction for changing illumination, but require careful matching of the spectral calibration and cross-calibration between two detectors.
<http://discover.asdi.com/bid/97740/Expert-Tip-Understand-Your-Field-of-View-When-Taking-Reference-Measurements>

Calculation of reflectance is simple, and follows equation 4 (above), if a primary standard is used. If the reflectance standard is a secondary standard that deviates substantially from the ideal (99% reflective) target, then an additional term may be needed in the equation:

$$\rho_{\lambda} = (R_{T,\lambda} / R_{SS,\lambda}) \times (R_{SS,\lambda} / R_{PS,\lambda}) \quad \text{eq. 5}$$

Where $R_{SS,\lambda}$ is the radiance of a secondary reflectance standard and $R_{PS,\lambda}$ is the radiance of a primary (99% reflective) standard. The second term represents a cross-calibration that can be readily obtained by comparing radiance of primary and secondary standards under identical light conditions (**Figure 12**).

By simultaneously collecting downwelling (irradiance) and upwelling (radiance) signals, dual detector systems (**Figure 11b**) provide a solution to unstable light conditions, but at the cost of an additional detector and added complexity. For example, a good match in the spectral calibration for the two detectors is needed; otherwise spurious features can be introduced into the spectra when calculating reflectance. A good cross-calibration (comparison of relative radiometric response, illustrated in **Figure 12**) between the two detectors is also needed for an accurate reflectance spectrum (see Gamon et al. 2006 and Gamon et al. 2015 for further discussion of cross calibration methods and effects). Since the relative radiometric properties of two detectors can change as illumination angle and sky conditions change (e.g. sunny vs. cloudy conditions), frequent cross-calibrations may be needed for accurate reflectance calculations. However, relative to single-detector systems that have large errors under unstable illumination, the errors resulting from

changing illumination when using dual-detector systems are relatively small, greatly improving the quality of the reflectance data obtained.

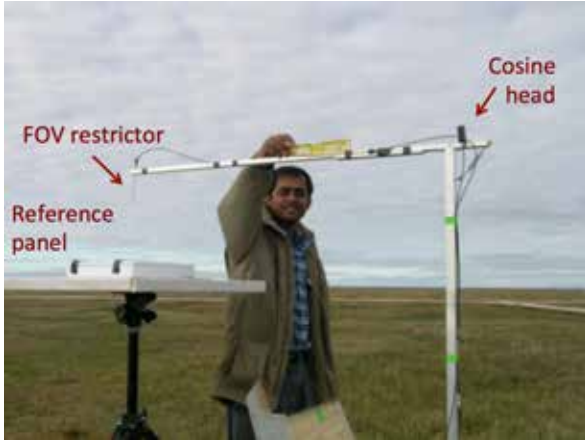

Figure 12 - Conducting a cross-calibration of a dual-detector spectrometer (UniSpec DC, PP Systems, Amesbury MA, USA) with an upward-looking fore-optic (fiber optic with cosine head, right arrow) and a downward looking fore-optic (fiber optic with FOV restrictor, left arrow) pointed at a reference panel. Cross-calibration corrects for changing sky conditions and enables accurate reflectance calculation, even under clouds. With this setup, two reference panels (a primary and secondary standard) are being compared to obtain the second term in eq. 5. Leveling of the sensors and panel helps standardize sampling geometry.

Relative to a single-detector system, a dual-detector system requires additional processing steps that correct for the different sensor responses to calculate reflectance. In this case, the ratio of the target radiance ($R_{T,\lambda}$) to the downwelling irradiance (I_λ) provides an uncorrected reflectance spectrum that needs to be further corrected by the cross calibration term ($I_\lambda / R_{S,\lambda}$). This cross-calibration consists of the ratio of the downwelling irradiance (I_λ) collected while simultaneously sampling the standard reference panel radiance ($R_{S,\lambda}$), as shown in equation 6.

$$\rho_\lambda = (R_{T,\lambda} / I_\lambda) \times (I_\lambda / R_{S,\lambda}) \quad \text{eq. 6}$$

These two terms, and their effects on the final corrected reflectance (ρ_λ) are shown in Figure 13, which also illustrates the effect of illumination (clear vs. cloudy conditions) on vegetation reflectance, with reflectance decreasing under cloudy (diffuse) conditions due to greater light penetration into the canopy. Thus, one benefit of dual-detector systems is that they enable detection of subtle changes in vegetation optical properties under changing illumination (Gamon et al. 2005, Gamon et al. 2015).

Figure 13

Uncorrected reflectance spectrum (the first term in equation 6, panel A) and the cross-calibration coefficient spectrum (the second term in equation 6, panel B) collected under sunny and cloudy sky conditions. The final reflectance is obtained by multiplying the two terms (as shown in eq. 6) to obtain the corrected reflectance spectrum shown in panel C. Note that sky conditions have a small effect on the reflectance due to the greater penetration of light into the canopy under diffuse (cloudy) conditions. Dashed lines indicate the range of “good data” (roughly 400-1000nm) due to low signal-to-noise causing aberrant patterns outside this range. Data for California chaparral vegetation at Sky Oaks, California, USA (Gamon et al. 2006).

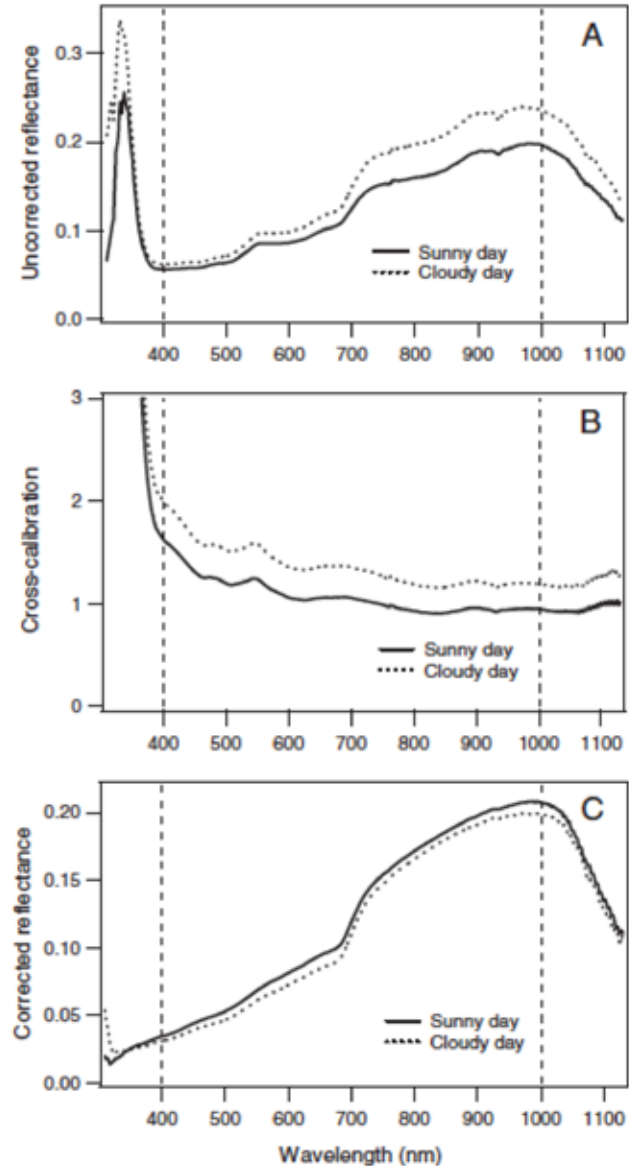

For sampling whole stands or landscapes from proximal remote sensing, mobile sampling platforms may be needed. Many kinds of mobile sampling methods can be used (Figure 14a-d), making direct comparison across methods difficult. As with all sampling, careful attention to sampling geometry and sampling scale (resolution and extent) is important for repeatable and comparable measurements.

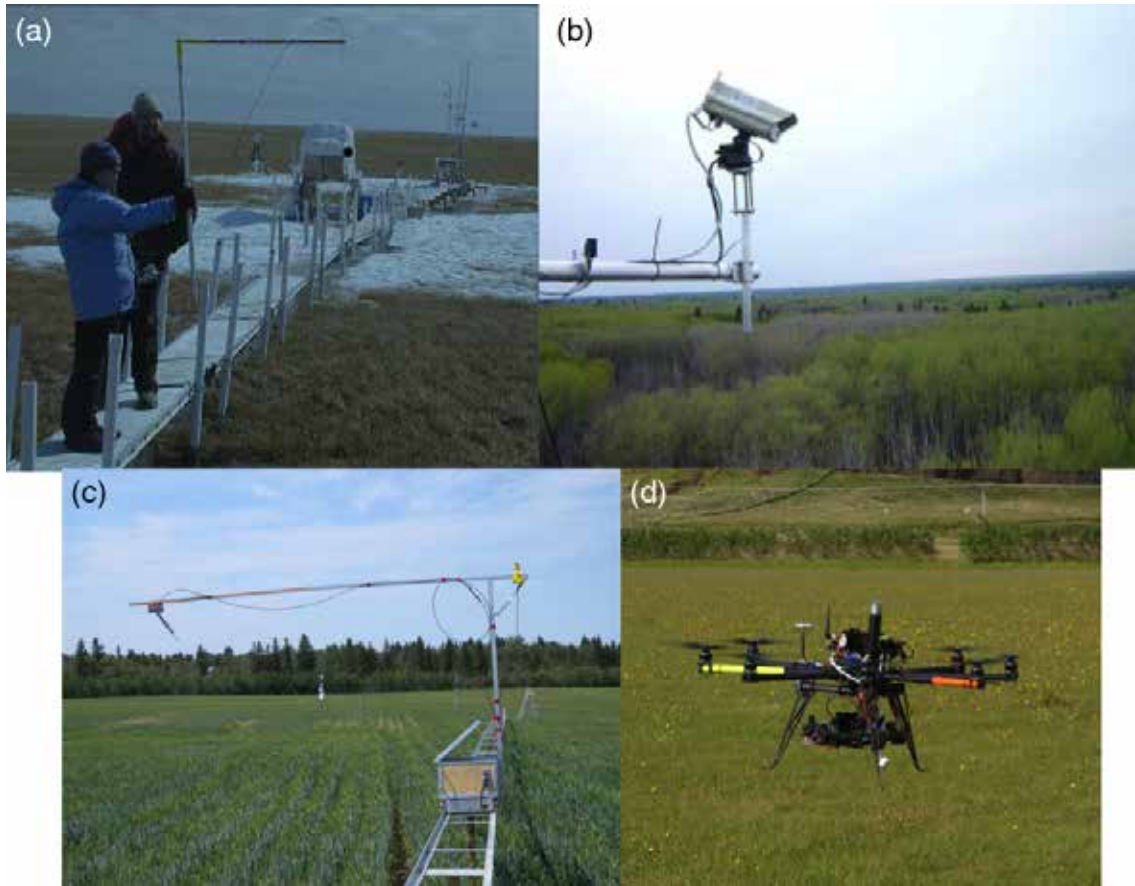

Figure 14 - Various mobile methods for sampling vegetation reflectance from whole stands, including a) hand sampling, b) rotating pan & tilt mount, c) robotic tram cart on a track, and d) drone (UAV). Each of these involves dual-detector sampling (Figure 11b) allowing correction for sky conditions. From Gamon 2015.

References Cited:

- Gamon JA (2015) Optical sampling of the flux tower footprint. *Biogeosciences* 12: 4509-4523. doi:10.5194/bg-12-4509-2015
- Gamon JA, Cheng Y, Claudio H, MacKinney L, Sims D (2006) A mobile tram system for systematic sampling ecosystem optical properties. *Remote Sensing of Environment*. 103:246-254
- Gamon JA, Surfus JS (1999) Assessing leaf pigment content and activity with a reflectometer. *New Phytologist* 143:105-117.
- Iqbal, M. (1983) *An Introduction to Solar Radiation*. Academic Press. New York.
- Milton EJ, Schaepman ME, Anderson K, Kneubuhler M, Fox N (2009) Progress in field spectroscopy. *Remote Sensing of Environment*. 113:S92-S109.
- Sandmeier et al. (1998) Sensitivity Analysis & Quality Assessment Of Laboratory BRDF data. *Remote Sensing of Environment*. 64:176-191
- Schaepman-Strub G, Schaepman ME, Painter TH, Dangel S, Martonchick JV. 2006, *Remote Sensing of Environment*. 103:27-42.

